

HY2

EXTERNAL GEAR PUMPS
GROUP 2

From 4.5 to 31.7 cc/rev
Up to 260 bar



Hydreco is pleased to introduce a brand new range of gear pumps. Based on the experience and knowledge acquired over many years of engineering and manufacturing, the HY series is provided with an aluminium alloy housing, two gear wheels supported by sleeve bearings and cast iron flange and cover.

The HY series, available as pumps and motors, offers high efficiency, low noise level and can be applied in standard and heavy duty application, thanks to the high reliability and the accuracy of design and production. The pumps can be supplied as single, or as multiple units with a huge variety of options on flanges, shafts and ports, providing the right setup on each application. Feel free to contact your Hydreco representative to find out more and to get the proper support in your selection.

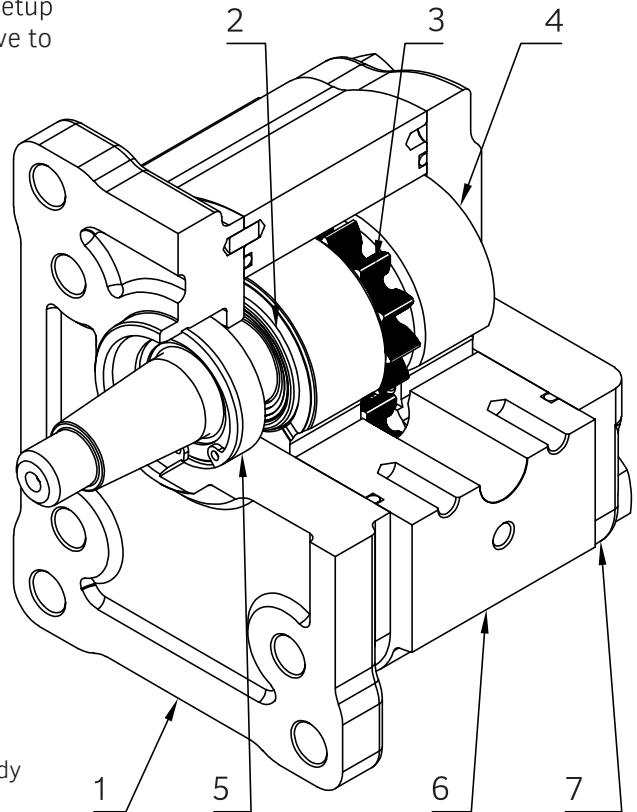

- 1 - Cast Iron Flange
- 2 - Gaskets
- 3 - Gears
- 4 - Bushings
- 5 - Shaft Seal
- 6 - Aluminium Alloy Body
- 7 - Cast Iron Cover

Displacements
From 4.5 cm³/rev to 31.7 cm³/rev
From 0.27 in³/rev to 1.93 in³/rev

Pressures
Max continuous 260 bar (3770 psi)
Max intermittent 290 bar (4200 psi)
Max peak 310 bar (4500 psi)

Max Speed
4000 rpm

HYDRECO
a member of **DAIKIN** group

Made in Italy

P/N H2200P023C

P C8+4-Z25P2

S/N D243019 05726



- H2200P023C = Pump / Motor part number - Clockwise rotation
- P or M = Pump or Motor
- P C08+04-Z25P2 = Abbreviate model code - Eg. Double pump, 8.2 cc + 4.5 cc, german flange 2 bolts Oring
- D243019 05726 = Serial number - Eg. D(month) - 24 (year) - 3019 (Production order) - 05726 (Id. number)
- Arrow = Direction of rotation
- QR Code = Complete model code

ORDERING CODE IDENTIFICATION FOR SINGLE PUMPS

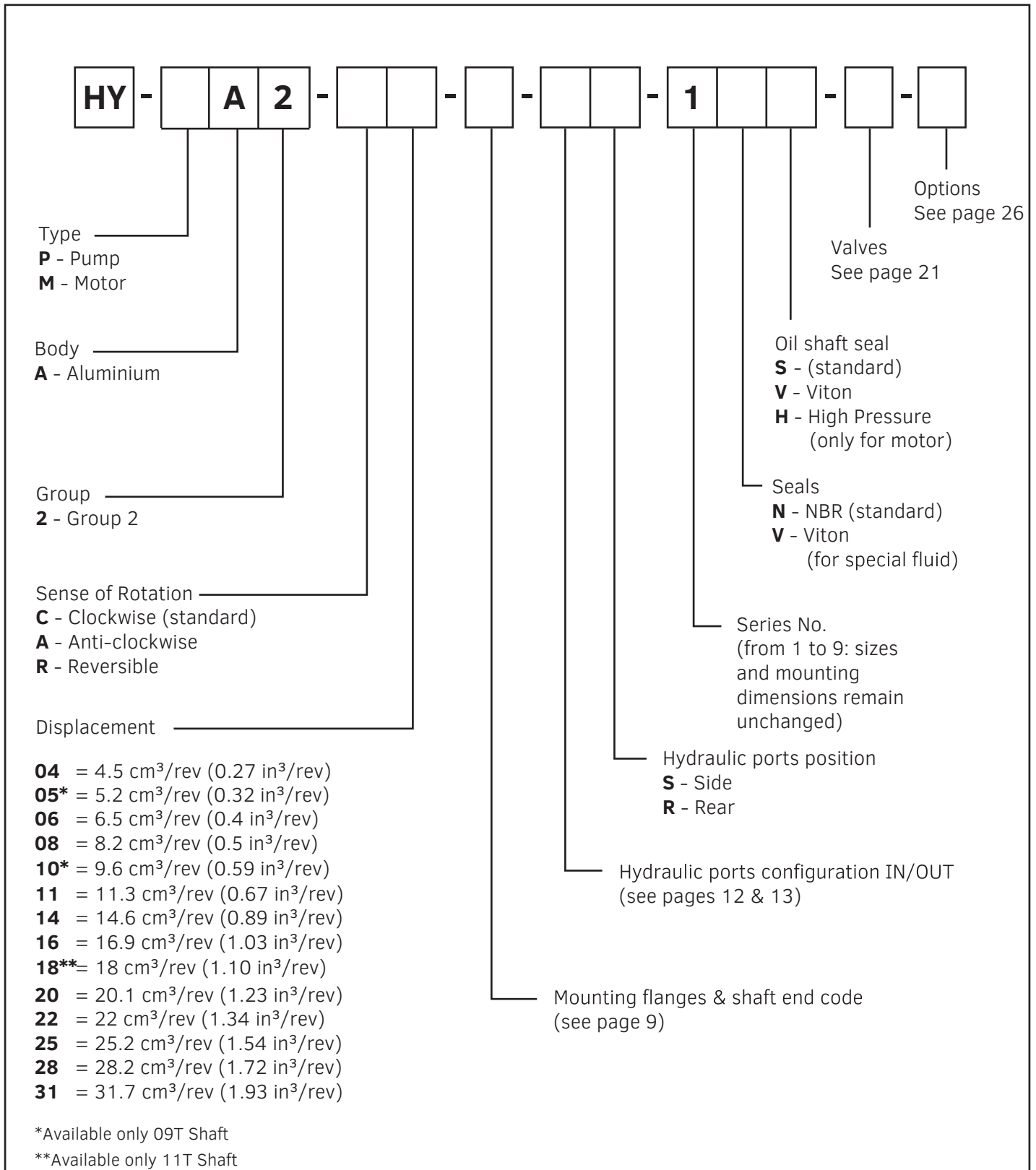

Example

HY-PA2-C08-E20T2-FE2/2S-1NS

ORDERING CODE IDENTIFICATION FOR ADDITIONAL STAGES ON MULTIPLE PUMPS

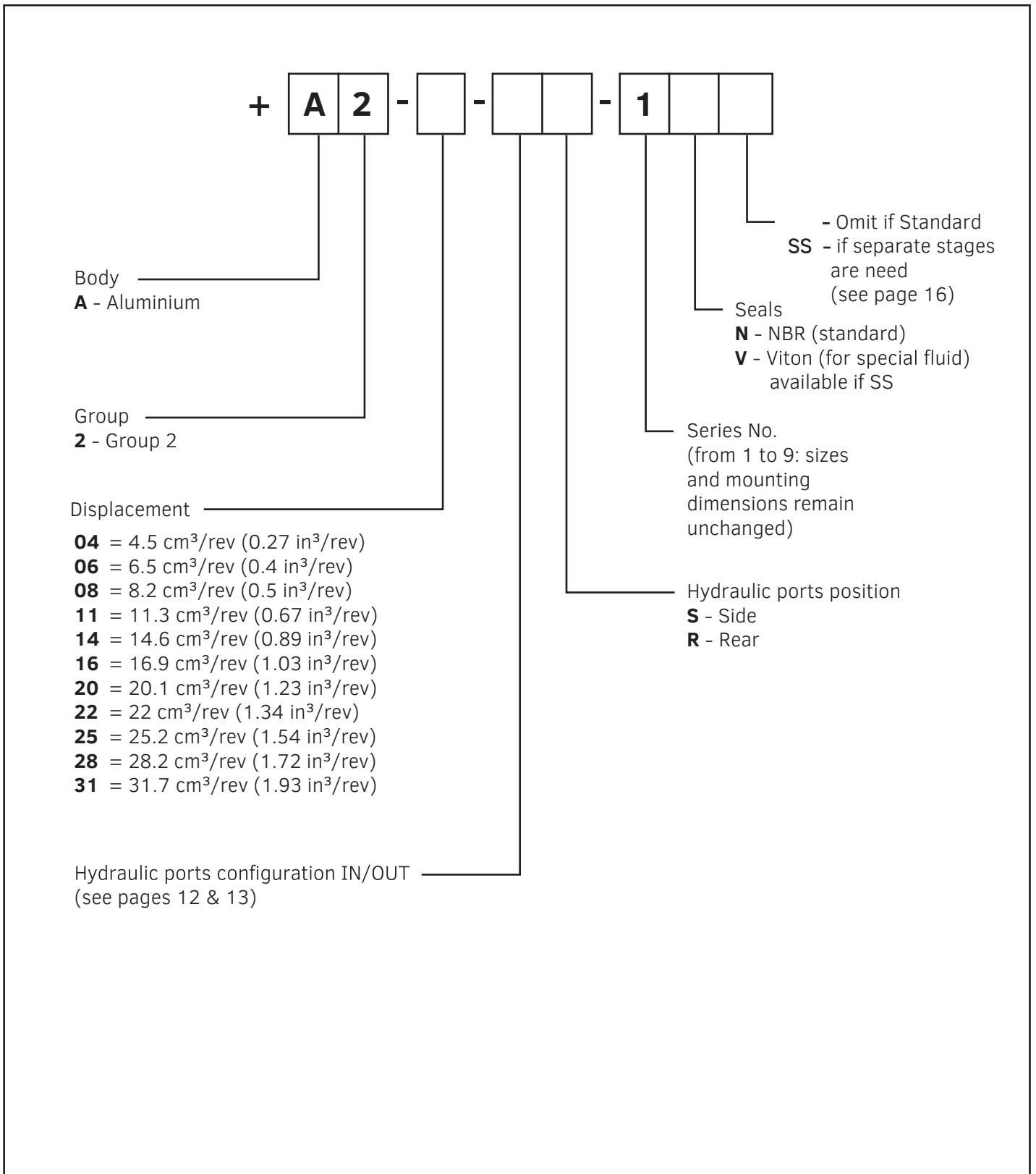

Example

HY-PA2-C08-E20T2-FE2/2S-1NS+A2-06-FE2/2S-1N

GROUP	SIZE	DISPLACEMENT cm ³ /rev (in ³ /rev)	MAX PRESSURE bar (psi)			SPEED rpm	
			P1	P2	P3	min	max
HY2	04	4.5 (0.27)	260 (3770)	290 (4200)	310 (4500)	600	4000
	05*	5.2 (0.32)	260 (3770)	290 (4200)	310 (4500)	600	4000
	06	6.5 (0.4)	260 (3770)	290 (4200)	310 (4500)	600	4000
	08	8.2 (0.5)	260 (3770)	290 (4200)	310 (4500)	600	4000
	10*	9.6 (0.59)	260 (3770)	290 (4200)	310 (4500)	600	4000
	11	11.3 (0.67)	260 (3770)	290 (4200)	310 (4500)	600	4000
	14	14.6 (0.89)	260 (3770)	290 (4200)	310 (4500)	500	3500
	16	16.9 (1.03)	260 (3770)	290 (4200)	310 (4500)	500	3200
	18*	18 (1.10)	240 (3480)	270 (3900)	290 (4200)	500	3000
	20	20.1 (1.23)	210 (3040)	240 (3480)	260 (3770)	500	3000
	22	22 (1.34)	200 (2900)	230 (3330)	250 (3620)	500	2700
	25	25.2 (1.54)	180 (2610)	210 (3040)	230 (3330)	500	2500
	28	28 (1.72)	160 (2320)	190 (2750)	210 (3040)	500	2200
31	31.7 (1.93)	150 (2170)	180 (2610)	200 (2900)	500	2000	

*Available only 09T Shaft

**Available only 11T Shaft

The data in the table refer to unidirectional pumps and motors.

The maximum pressures of reversible pumps and motors are 15% lower than unidirectional ones.

For different working conditions please contact Hydreco technical support.

GENERAL CHARACTERISTICS

ROTATION DIRECTION

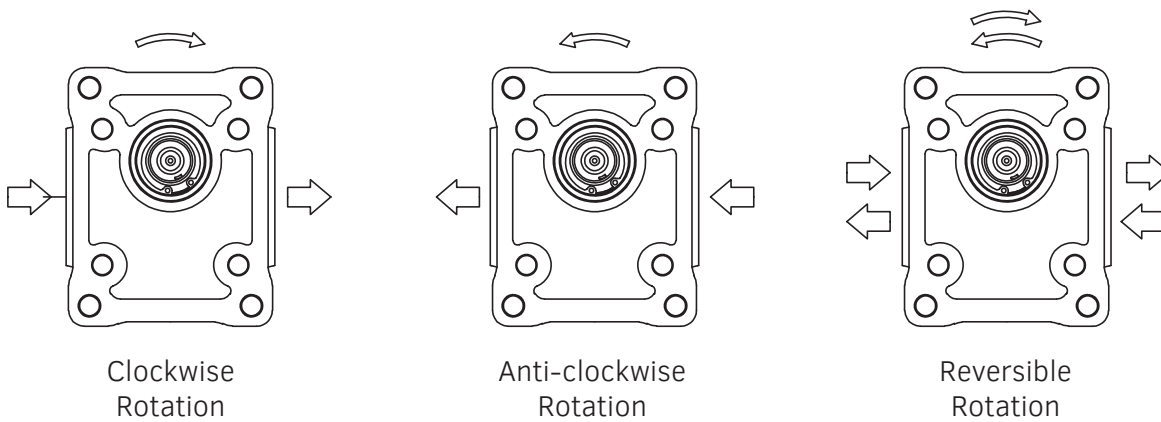

DEFINITION OF PRESSURES

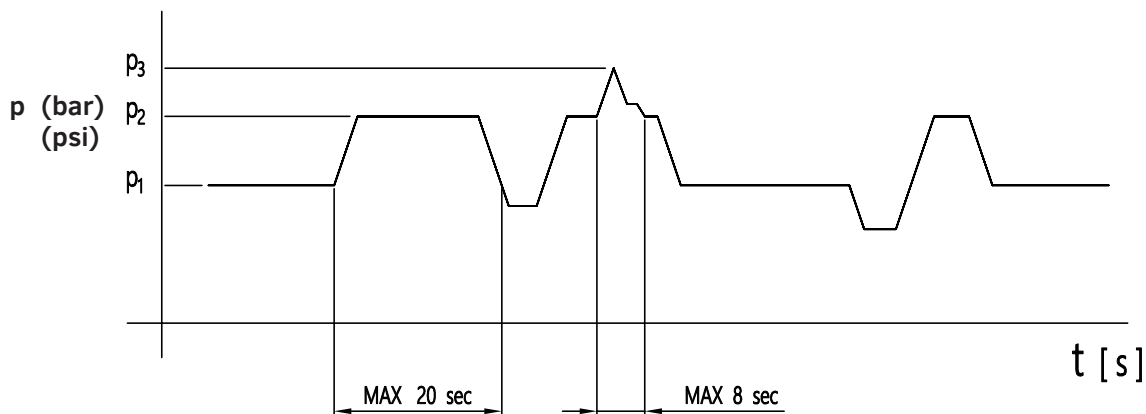

- p_1 Max continuous pressure
- p_2 Max intermittent pressure
- p_3 Max peak pressure

GENERAL CHARACTERISTICS

It is essential that pumps are installed so that they can always fill with fluid. 'HY' Series pumps inlet porting is designed to facilitate full volume fill but the following machine design recommendations should be followed.

Direction of rotation (Viewed from shaft end)	Clockwise (C) – Anticlockwise (A) – Reversible (R)
Range inlet pressure – pump	0.7 ÷ 3 bar (10 ÷ 43 psi)
Max back pressure on the unidirectional motors and reversible with internal drainage	P ₁ (continue) max 5 bar (72 psi) P ₂ (for 20 sec) max 8 bar (115 psi) P ₃ (for 5 sec) max 15 bar (215 psi)
Reversible Motor Max pressure in drain	5 bar
Temperature fluid (MIN, MAX, PEAK) °C	-25, 80, 100 NBR -25, 110, 125 VITON
Range of viscosity	From 10 to 100 mm ² /s (cSt) IDEAL Up to 750 mm ² /s (cSt) RECOMMENDED Up to 1000 mm ² /s (cSt) START
Fluid type	Mineral oil

RECOMMENDED FILTRATION

Working pressure bar (psi)	$\Delta p < 140$ (2030)	140 (2030) < $\Delta p < 210$ (3040)	$\Delta p > 210$ (3040)
Class contamination NAS 1638	10	9	8
Class contamination ISO 4406:1999	21/19/16	20/18/15	19/17/14

- Q = flow rate (L/min)
- V = displacement (cm³/rev)
- n = speed (min⁻¹)
- M = torque (Nm)
- P = power (kW)
- Δp = pressure (bar)

	PUMPS	MOTORS
PERFORMANCE		
η_v = volumetric efficiency	≈ 0.96	≈ 0.95
η_{hm} = hydro-mechanical efficiency	≈ 0.88	≈ 0.85
η_t = total efficiency	≈ 0.84	≈ 0.81

DETERMINATION OF A PUMP

$$Q_{\text{theor}} = \frac{V \times n}{1000} \text{ (l/min)}$$

$$Q_{\text{real}} = Q_{\text{theor}} \times \eta_v$$

$$M_{\text{real}} = \frac{M_{\text{theor}}}{\eta_{\text{hm}}} \text{ (Nm)}$$

$$M_{\text{theor}} = \frac{\Delta p \times V}{62.8} \text{ (Nm)}$$

$$P_{\text{OUT}} = \frac{\Delta p \times Q}{600} \text{ (kW)}$$

$$P_{\text{IN}} = \frac{P_{\text{OUT}}}{\eta_t}$$

DETERMINATION OF A MOTOR

$$Q_{\text{theor}} = \frac{V \times n}{1000} \text{ (l/min)}$$

$$Q_{\text{real}} = \frac{Q_{\text{theor}}}{\eta_v}$$

$$M_{\text{theor}} = \frac{\Delta p \times V}{62.8} \text{ (Nm)}$$

$$M_{\text{real}} = M_{\text{theor}} \times \eta_{\text{hm}}$$

$$P_{\text{OUT}} = \frac{\Delta p \times Q}{600} \text{ (kW)}$$

$$P_{\text{IN}} = P_{\text{OUT}} \times \eta_t$$

PUMP SELECTION

Curves at 40°C - fluid viscosity 46 mm²/sec

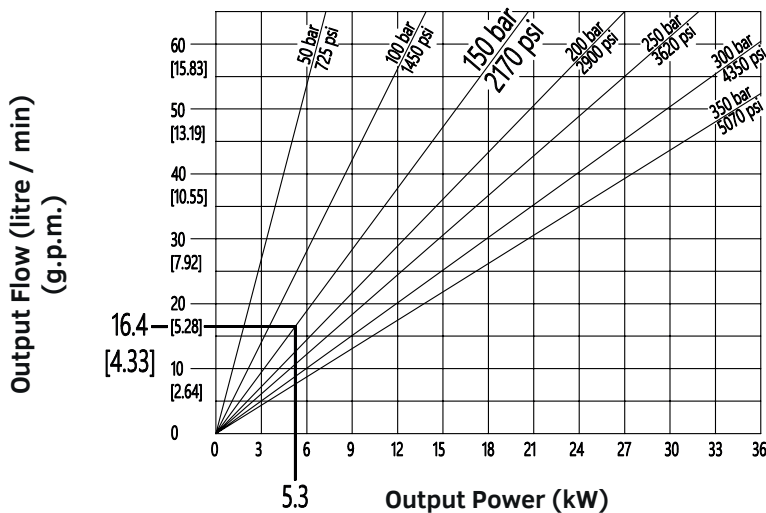
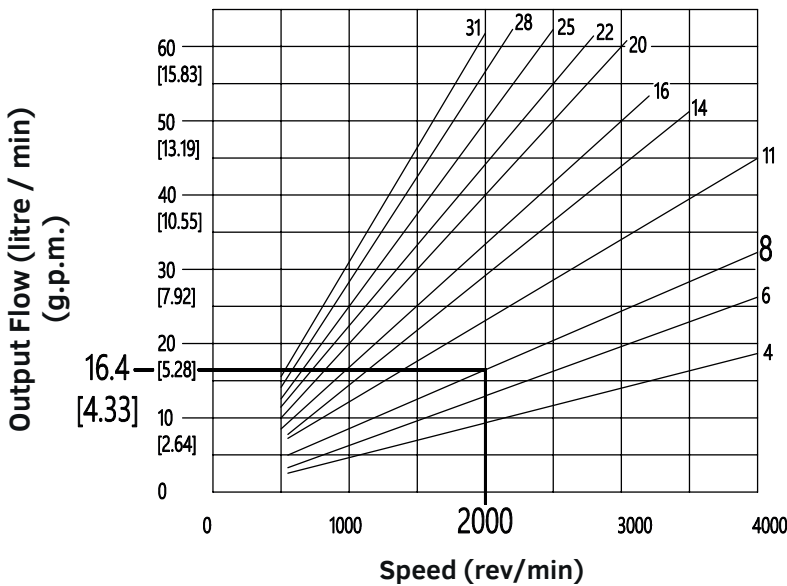

Example

Working conditions:

Pump 8.2cc

Speed 2000 r.p.m.

Pressure: 150 bar [2170 psi]

Motor: 5.3 kW

OUTPUT FLOWS are theoretical.

Generally volumetric efficiencies are in excess of 95%.

Please contact your Hydreco representative for specific working conditions.

INPUT POWERS are theoretical taking into account average efficiencies.

NOTE:

Diagrams provide approximate selection data

MOTOR SELECTION

Curves at 40°C – fluid viscosity 46 mm²/sec – 2000r.p.m.

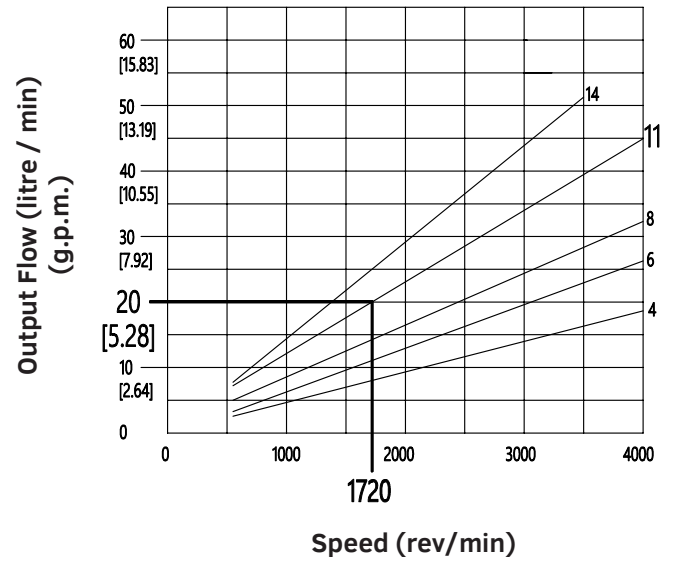
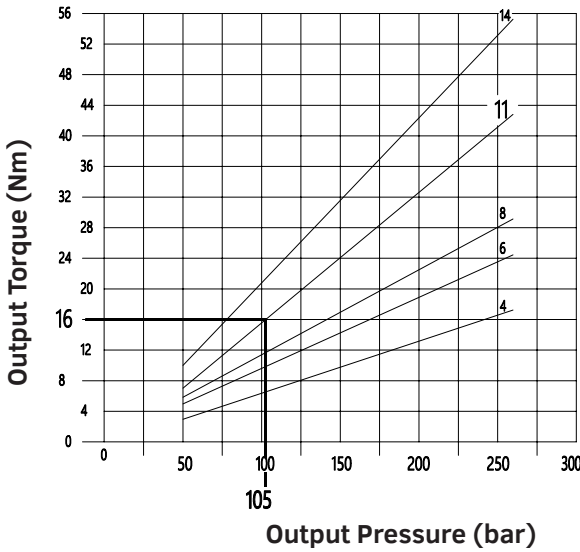

NOTE:

Diagrams provide approximate selection data

Example

Working conditions:
Torque needed: 16 Nm
Available flow 20 litre/min
Necessary motor: 8 (8.2cc)
Pressure working: 105 bar
Speed: 1720 rev/min

MOTOR SELECTION

Curves at 40°C – fluid viscosity 46 mm²/sec – 1500r.p.m.

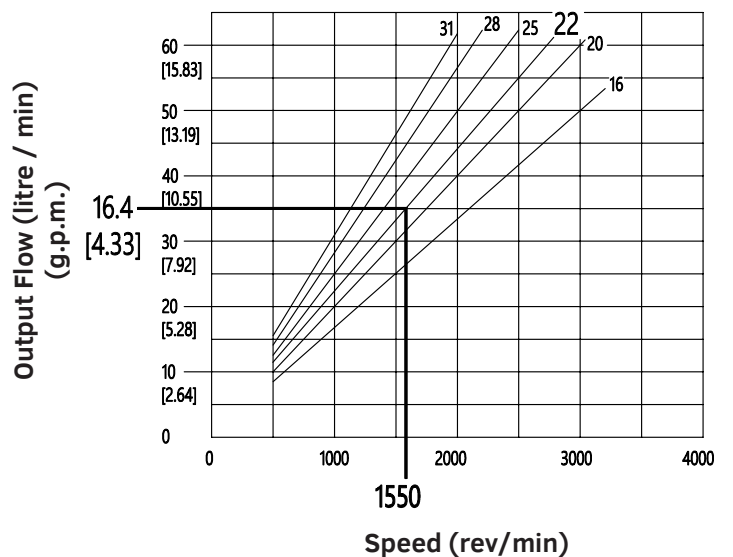
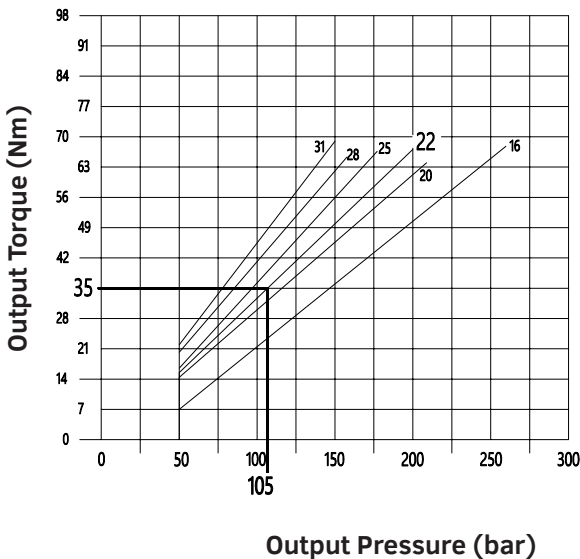

NOTE:

Diagrams provide approximate selection data

Example

Working conditions:
Torque needed: 35 Nm
Available flow 35 litre/min
Necessary motor: 22 (22cc)
Pressure working: 105 bar
Speed: 1550 rev/min

EUROPEAN standard CODE	FLANGE	SHAFT
E20T2	E20 = European flange pilot Ø36.5	T2 = Tapered shaft 1:8 M12

GERMAN standard CODES	FLANGE	SHAFT
G20T6	G20 = German flange pilot Ø80	T6 = Tapered shaft 1:5 M12
G20T9	G20 = German flange pilot Ø80	T9 = Splined shaft 9T - DIN 5482
Z23T6	Z23 = German flange 2 bolts fixing holes on NE-SW	T6 = Tapered shaft 1:5 M12
Z24T6	Z24 = German flange 2 bolts fixing holes on NW-SE	T6 = Tapered shaft 1:5 M12
Z25P2	Z25 = German flange 2 bolts o.ring on spigot fixing holes on NE-SW	P2 = Tang shaft
Z26P2	Z26 = German flange 2 bolts o.ring on spigot fixing holes on NW-SE	P2 = Tang shaft

AMERICAN standard CODES	FLANGE	SHAFT
A09T	A = SAE A flange Ø82	09T = Splined shaft 9T 16/32
A11T	A = SAE A flange Ø82	11T = Splined shaft 11T 16/32
A058P	A = SAE A flange Ø82	058P = Parallel shaft Ø15.85

For other configurations than those indicated, please contact Hydreco technical support.

FLANGES OPTIONS

<p>Code E20 EUROPEAN</p>	<p>Code G20 GERMAN</p>
<p>Code A SAE (A) - 2 BOLTS</p>	Empty space for drawing
Empty space for drawing	Empty space for drawing

FLANGES OPTIONS

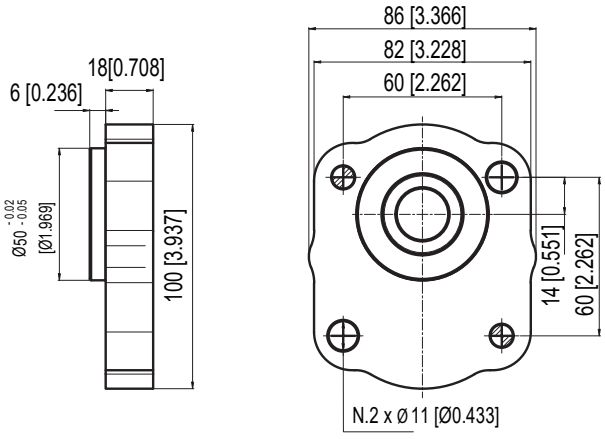
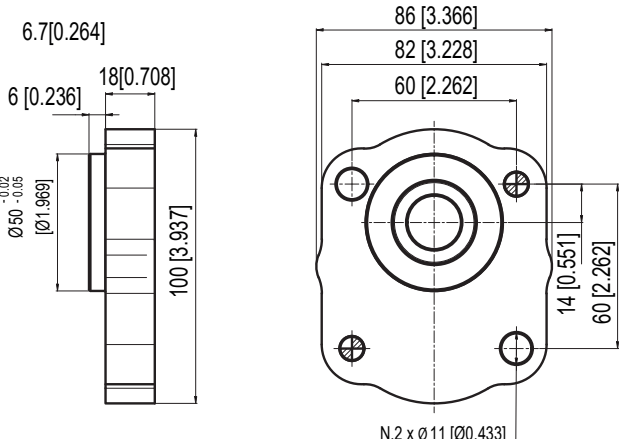
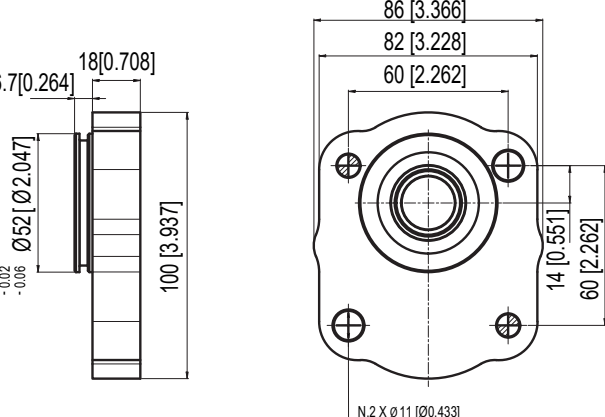
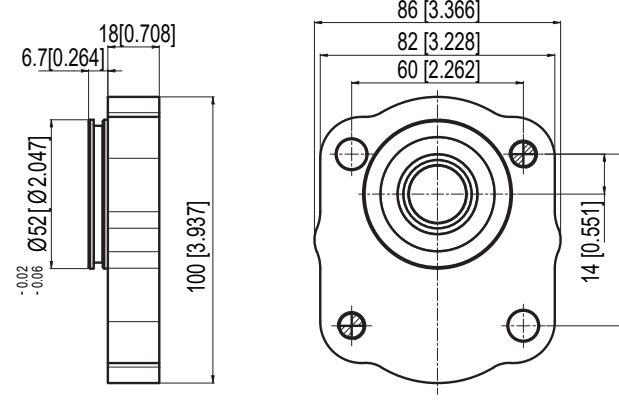
<p>Code Z23 GERMAN FLANGE - 2 BOLTS</p> 	<p>Code Z24 GERMAN FLANGE - 2 BOLTS</p> 
<p>Code Z25 GERMAN FLANGE - 2 BOLTS</p> 	<p>Code Z26 GERMAN FLANGE - 2 BOLTS</p> 

SHAFT OPTIONS

<p>Code 09T SAE (A) 5/8" spline</p> <p>Involute Spline 9 teeth – 16/32 DP Flat root, side fit 30 deg pressure angle</p> <p>Max Torque = 100 Nm (885 lbf in)</p>	<p>Code 11T SAE (A) 3/4" spline</p> <p>Involute Spline 11 teeth – 16/32 DP Flat root, side fit 30 deg pressure angle</p> <p>Max Torque = 170 Nm (1505 lbf in)</p>
<p>Code 058P SAE (A) 5/8" parallel</p> <p>Max Torque = 70 Nm (620 lbf in)</p>	<p>Code T2 European Tapered 1:8</p> <p>Max Torque = 140 Nm (1240 lbf in)</p>

Please note:

Shaft 11T, 058P, T2 available on request for quantities for displacements 05,10

Shaft 09T, 058P, T2 available on request for quantities for displacements 18

SHAFT OPTIONS

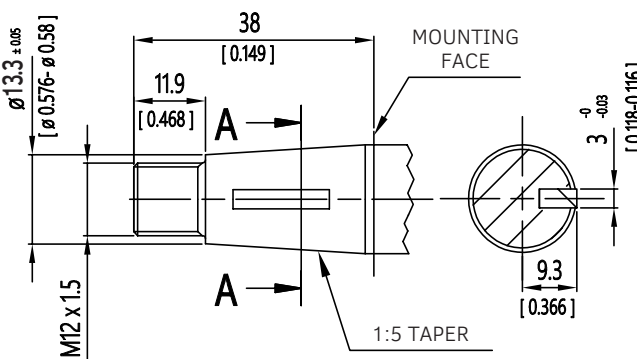
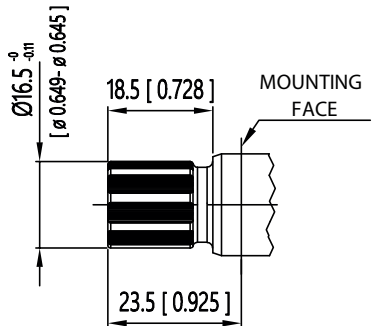
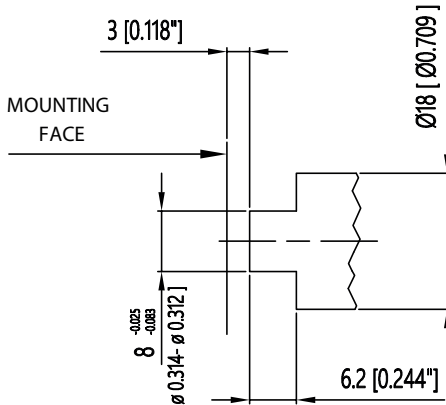
<p>Code T6 German Tapered 1:5</p>  <p>Max Torque = 140 Nm (1240 lbf in)</p>	<p>Code T9 9T - DIN5482</p> <p>Ext. Involute Spine B 17 x 14 x e9 DIN 5482</p>  <p>Max Torque = 110 Nm (974 lbf in)</p>
<p>Code P2 Tang shaft</p>  <p>Max Torque = 70 Nm (620 lbf in)</p>	

Please note:

Shaft T6 T9 P2 available on request for quantities for displacements 05,10,18

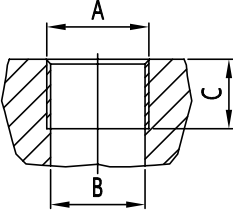
BSPP THREADED PORTS (B) Compliant with ISO 228	Ordering Code	Dimension mm (inches)			Tightening Torque Nm [lbf in]	
		A	B	C	Low Pressure	High Pressure
	2	1/2"	19 (0.748)	14 (0.551)	20 [180]	50 [440]
	3	3/4"	24 (0.944)	18 (0.708)	30 [265]	80 [710]
	4	1"	30 (1.181)	22 (0.866)	50 [440]	120 [1060]

STANDARD PORT CONFIGURATION				
CODE	SUCTION	PRESSURE	POSITION	SIZE
B2/2S	2 = 1/2" BSPP	2 = 1/2" BSPP	S = SIDE	4 to 8
B3/2S	3 = 3/4" BSPP	2 = 1/2" BSPP	S = SIDE	10 to 31
B2/2R	2 = 1/2" BSPP	2 = 1/2" BSPP	R = REAR	4 to 8
B3/2R	3 = 3/4" BSPP	2 = 1/2" BSPP	R = REAR	10 to 31

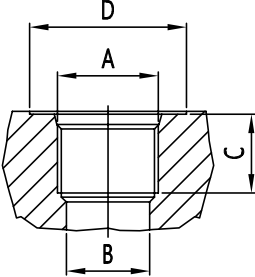
SAE THREADED PORTS (U) Compliant with SAE J514	Ordering Code	Dimensions mm (inches)				Tightening Torque Nm [lbf in]	
		A	B	C	D	Low Pressure	High Pressure
	25	7/8" - 14 UNF	20 (0.787)	17 (0.669)	35 (1.377)	30 [265]	70 [620]
	3	1 1/16" - 12 UNF	24 (0.944)	17 (0.669)	42 (1.653)	40 [355]	120 [1060]

STANDARD PORTS CONFIGURATION				
CODE	SUCTION	PRESSURE	POSITION	SIZE
U25/25S *	25 = 7/8" 14 UNF	25 = 7/8" 14 UNF	S = SIDE	4 to 11
U3/25S *	3 = 1 1/16" 12 UNF	25 = 7/8" 14 UNF	S = SIDE	14 to 31
U25/25R *	25 = 7/8" 14 UNF	25 = 7/8" 14 UNF	R = REAR	4 to 11
U3/25R *	3 = 1 1/16" 12 UNF	25 = 7/8" 14 UNF	R = REAR	14 to 31

Please note (*):

U ports available on size 5,10,18 only on request. Please contact Hydreco technical support

INLET PORTS = For multiple pumps with single inlet please contact Hydreco technical support

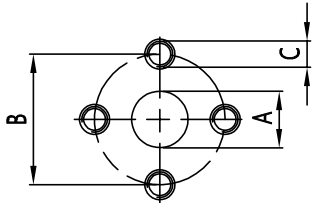
EUROPEAN FLANGED PORTS (FE)	Ordering Code	Dimensions mm (inches)			Tightening Torque Nm [lbf in]	
		A	B	C	Low Pressure	High Pressure
	2	13 (0.511)	30 (1.181)	M6	8 [70]	8 [70]
	3	20 (0.787)	40 (1.574)	M8	15 [130]	15 [130]

STANDARD PORTS CONFIGURATION				
CODE	SUCTION	PRESSURE	POSITION	SIZE
FE2/2S *	2 = Ø13 mm	2 = Ø13 mm	SIDE (only)	4 to 8
FE3/2S *	3 = Ø20 mm	2 = Ø13 mm	SIDE (only)	11 to 31

Please note (*):

Ports available on size 5,10,18 only on request. Please contact Hydreco technical support

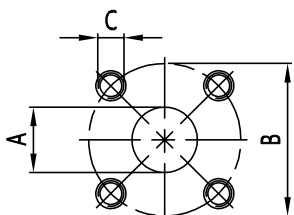
GERMAN FLANGED PORTS (FG)	Ordering Code	Dimensions mm (inches)			Tightening Torque Nm [lbf in]	
		A	B	C	Low Pressure	High Pressure
	25	15 (0.59)	35 (1.377)	M6	8 [70]	8 [70]
	3	20 (0.787)	40 (1.574)	M6	8 [70]	8 [70]

STANDARD PORTS CONFIGURATION				
CODE	SUCTION	PRESSURE	POSITION	SIZE
FG3/25S *	3 = Ø20 mm	25 = Ø15 mm	SIDE (only)	ALL

Please note (*):

Ports available on size 5,10,18 only on request. Please contact Hydreco technical support

INLET PORTS = For multiple pumps with single inlet please contact Hydreco technical support

SAE FLANGED PORTS - 51B (SM)	Ordering Code	Dimensions mm (inches)				Tightening Torque Nm [lbf in]	
		A	B	C	D	Low Pressure	High Pressure
	2	12.5 (0.472)	38.1 (1.50)	17.5 (0.687)	M8	15 [133]	20 [180]
	3	19 (0.748)	47.6 (1.874)	22.2 (0.874)	M10	20 [180]	35 [320]
	4	25.4 (1.00)	52.4 (2.063)	26.2 (1.031)	M10	20 [180]	35 [320]

STANDARD PORTS CONFIGURATION				
CODE	SUCTION	PRESSURE	POSITION	SIZE
SM 2/2S	2 = Ø12.5 mm	2 = Ø12.5 mm	vertical	4 to 16
SM 3/2S	3 = Ø19 mm	2 = Ø12.5 mm	horizontal	20 to 22
SM 4/3S	4 = Ø25.4 mm	3 = Ø19 mm	horizontal	25 to 31

INLET PORTS = For multiple pumps with single inlet please contact Hydreco technical support

PORTS OPTIONS

HY2 - STANDARD PORTS								
	PUMP/MOTOR UNI-DIRECTIONAL				PUMP/MOTOR REVERSIBLE			
PORTS TYPE	B	FE	FG	U	B	FE	FG	U
Displacement								
04	2/2	2/2	3/25	25/25	2/2	2/2	3/25	25/25
06	2/2	2/2	3/25	25/25	2/2	2/2	3/25	25/25
08	2/2	2/2	3/25	25/25	2/2	2/2	3/25	25/25
11	3/2	3/2	3/25	25/25	3/3	3/3	3/25	25/25
14	3/2	3/2	3/25	3/25	3/3	3/3	3/25	3/25
16	3/2	3/2	3/25	3/25	3/3	3/3	3/25	3/25
20	3/2	3/2	3/25	3/25	3/3	3/3	3/25	3/25
22	3/2	3/2	3/25	3/25	3/3	3/3	3/25	3/25
25	3/2	3/2	3/25	3/25	3/3	3/3	3/25	3/25
28	3/2	3/2	3/25	3/25	3/3	3/3	3/25	3/25
31	3/2	3/2	3/25	3/25	3/3	3/3	3/25	3/25

SINGLE PUMPS

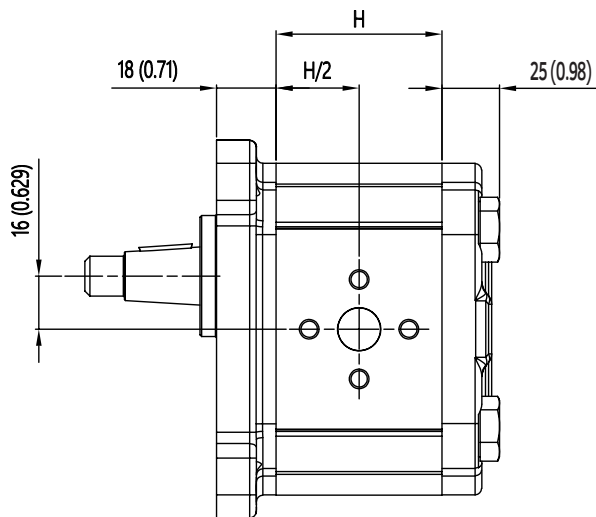
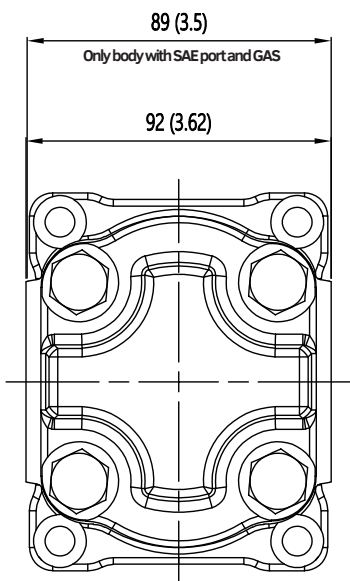

UNIDIRECTIONAL COVER

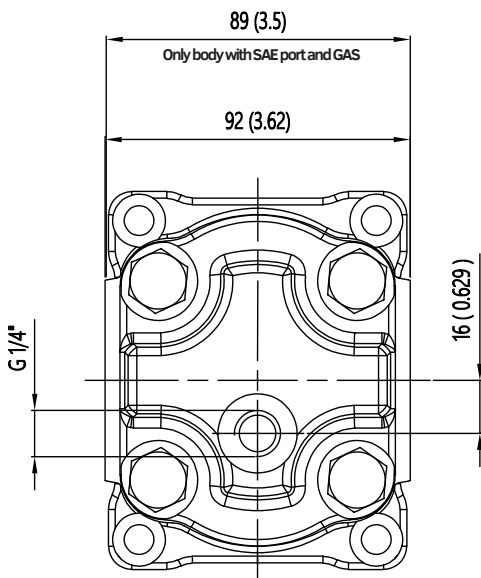

GROUP	PUMP / MOTOR SIZE	H mm (inches)	WEIGHT (Kg)
HY2	04	48.6 (1.913)	3.4
	05	49.7 (1.957)	3.4
	06	51.5 (2.027)	3.4
	08	54.0 (2.125)	3.5
	10	56.5 (2.224)	3.5
	11	58.4 (2.299)	3.5
	14	63.2 (2.488)	3.6
	16	66.6 (2.622)	3.6
	18	68.2 (2.685)	3.7
	20	71.3 (2.807)	3.8
	22	82.0 (3.228)	4.2
	25	86.6 (3.409)	4.2
	28	91.0 (3.582)	4.5
	31	96.1 (3.783)	4.5

REVERSIBLE COVER

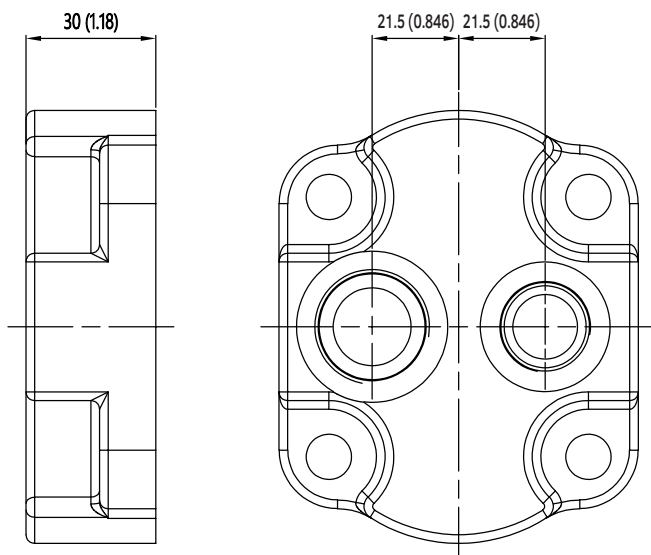

Indicative weights - European flange and 1:8 tapered shaft

Available rear ports: BSPP and SAE (see page 12)

DIMENSIONS (side view)

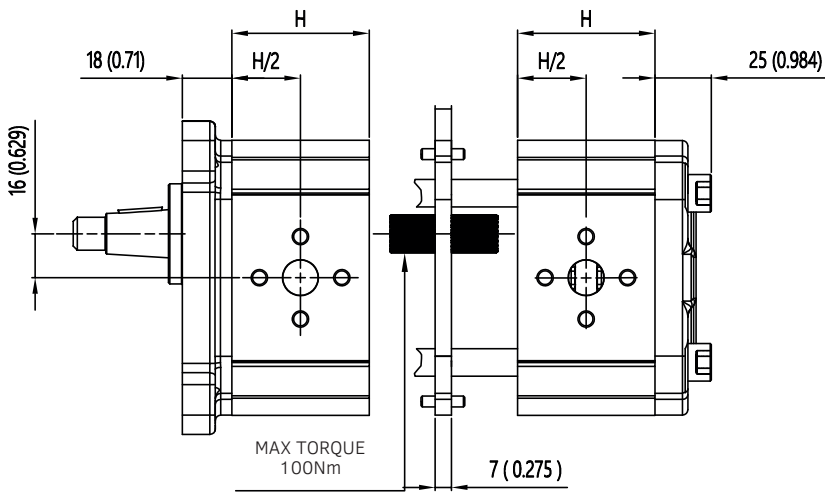
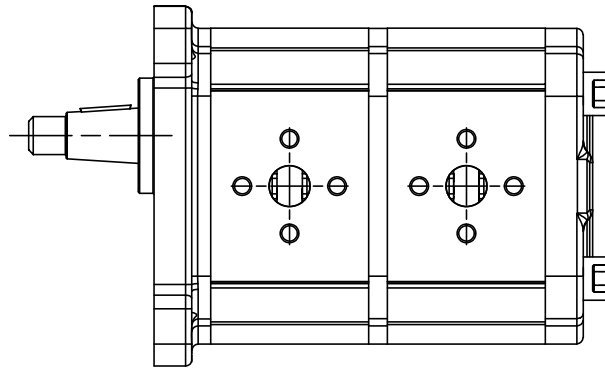

STANDARD CONFIGURATION
tandem pumps

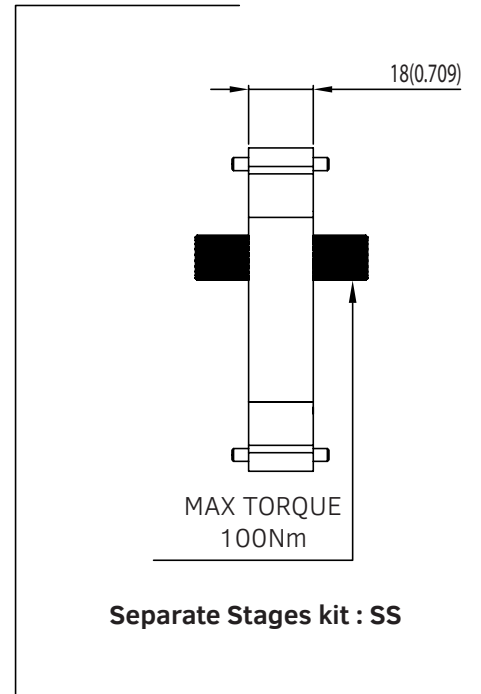

Separate Stages kit : SS

GROUP	PUMP SIZE	H mm (inches)	PUMP TYPE	H mm (inches)
HY2	04	48.6 (1.913)	20	71.3 (2.807)
	06	51.5 (2.027)	22	82.0 (3.228)
	08	54.0 (2.125)	25	86.6 (3.409)
	11	58.4 (2.299)	28	91.0 (3.582)
	14	63.2 (2.488)	31	96.1 (3.783)
	16	66.6 (2.622)		

TANDEM PUMPS SCREW LENGTHS

SIZE cc Gr.2	04	06	08	11	14	16	20	22	25	28	31
04	135	140	140	145	150	155	160	170	175	180	185
06		145	145	150	155	155	160	175	175	180	185
08			145	150	155	160	165	175	180	185	190
11				155	160	165	170	180	185	190	195
14					165	170	175	185	190	195	200
16						170	175	190	190	200	200
20							180	190	200	200	205
22								200	200	210	215
25									210	215	220
28										220	225
31											230

TANDEM PUMPS HY2+HY2
M10 screws size
10.9 screws class
Screws Tightening Torque = 60 +/- 2 Nm
Length expressed in millimeters

EXAMPLES WITH COMMON INLET (top view)

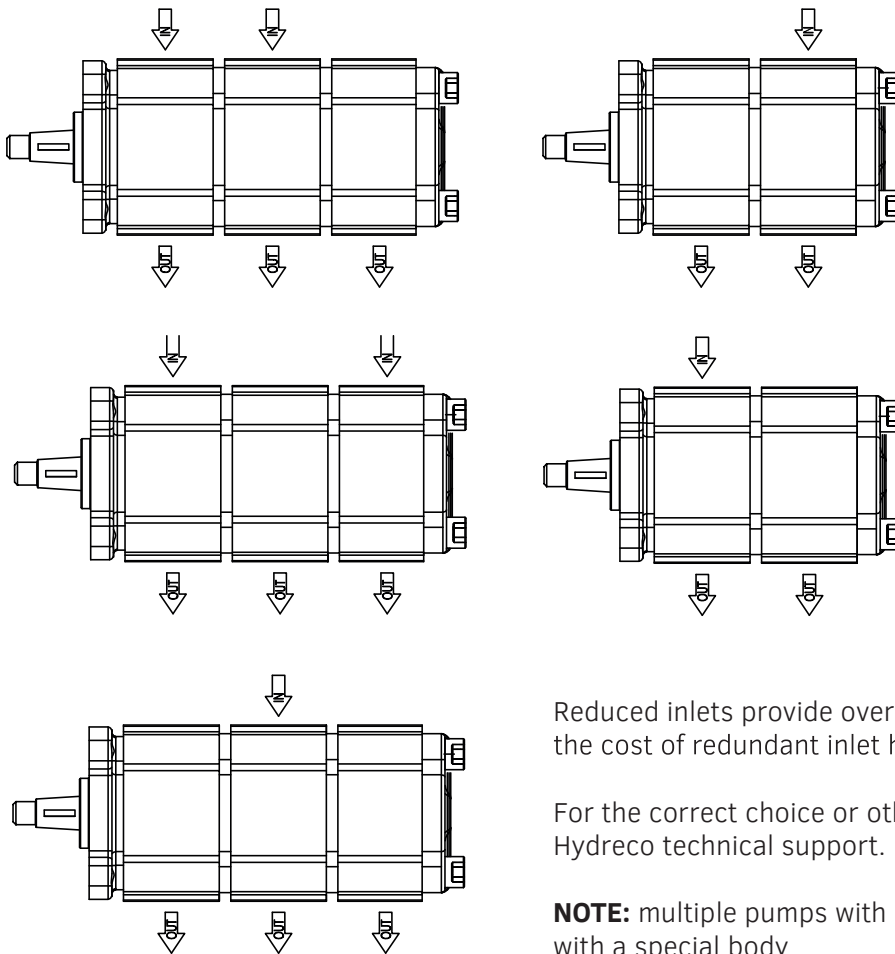

Reduced inlets provide overall systems savings by reducing the cost of redundant inlet hose and fittings.

For the correct choice or other combinations please contact Hydreco technical support.

NOTE: multiple pumps with common inlet will be provided with a special body

DIMENSIONS (side view)

The HY2 intermediate pumps include the intermediate flange & coupling to easily assemble tandem or multiple pumps.

GROUP	PUMP SIZE	H mm (inches)	PUMP SIZE	H mm (inches)
HY2	04	48.6 (1.913)	20	71.3 (2.807)
	06	51.5 (2.027)	22	82.0 (3.228)
	08	54.0 (2.125)	25	86.6 (3.409)
	11	58.4 (2.299)	28	91.0 (3.582)
	14	63.2 (2.488)	31	96.1 (3.783)
	16	66.6 (2.622)		

MAX TORQUE 100Nm

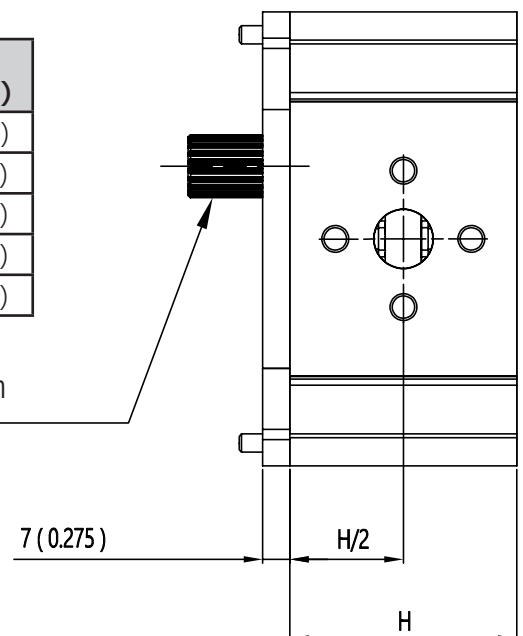

ORDERING CODE IDENTIFICATION FOR STAND ALONE INTERMEDIATE PUMPS

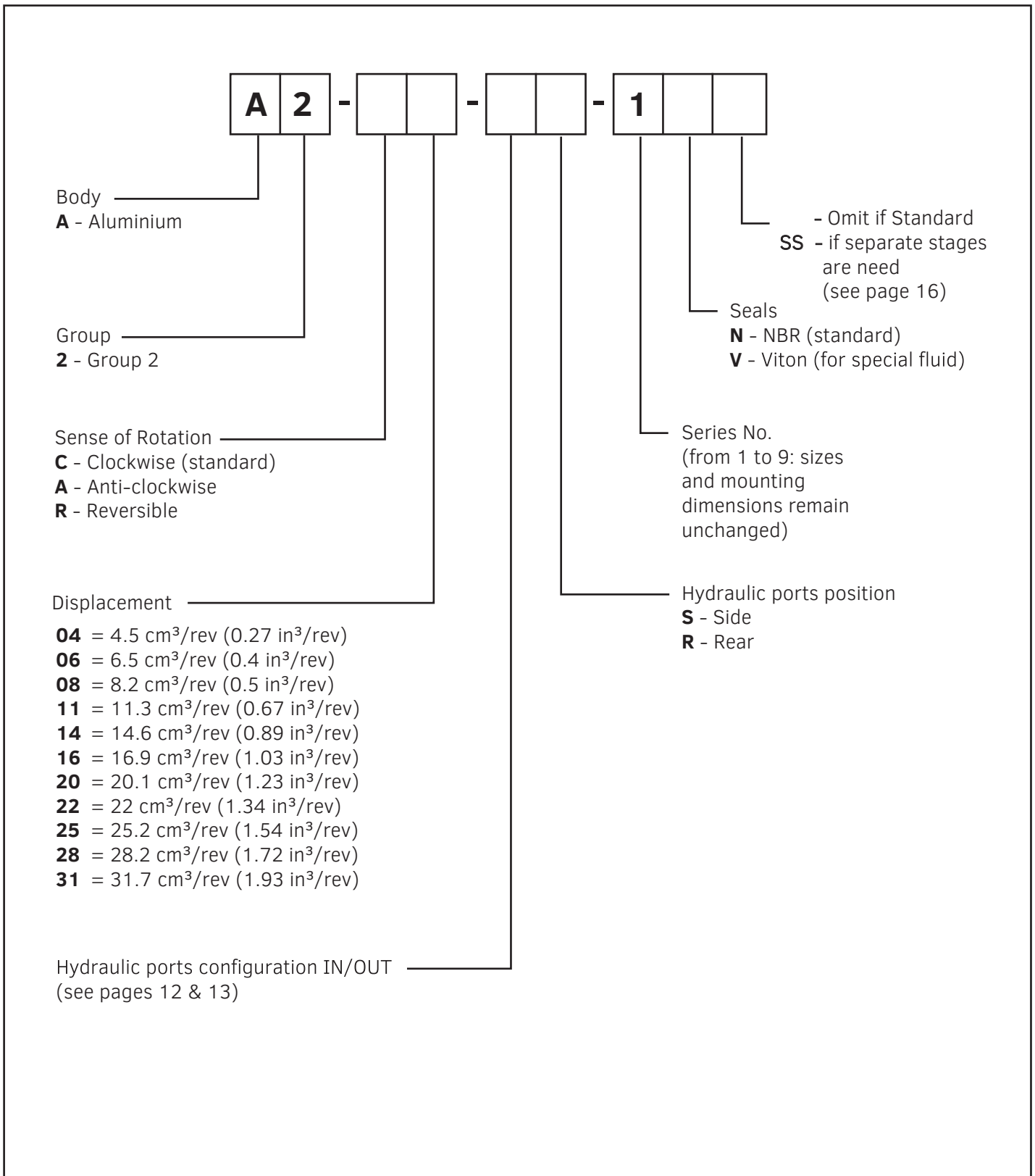

Example

A2-C06-FE2/2S-1N

HOW TO MAKE TANDEM PUMPS USING AN INTERMEDIATE PUMP (side view)

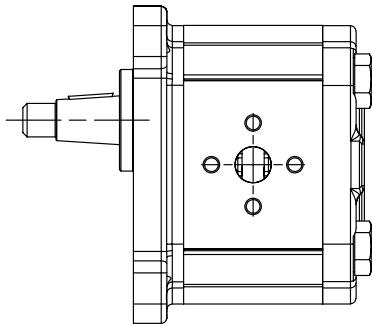

STANDARD PUMP

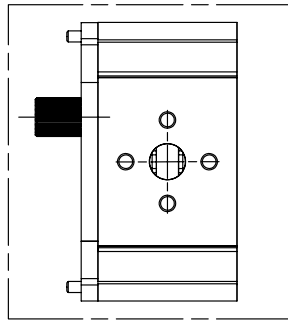

INTERMEDIATE PUMP

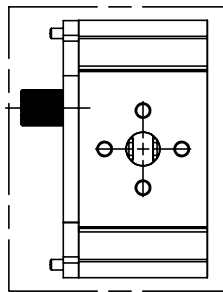
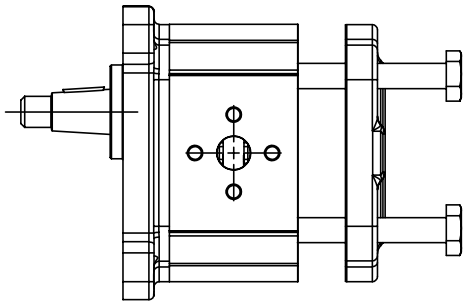

A. Loosen, and remove, the clamp screws and remove the cover.

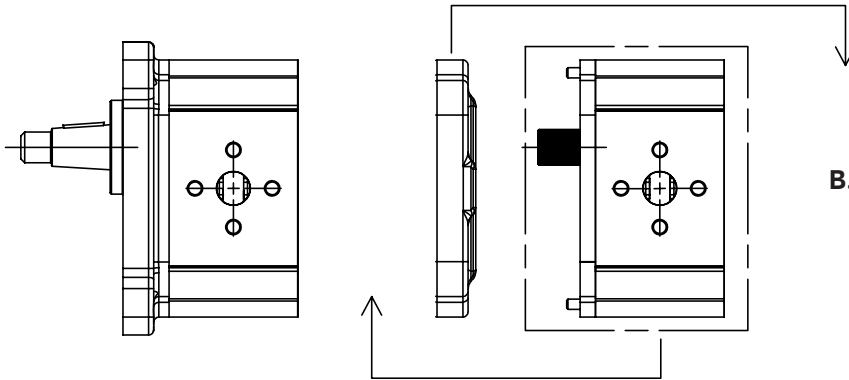

B. Connect the intermediate pump

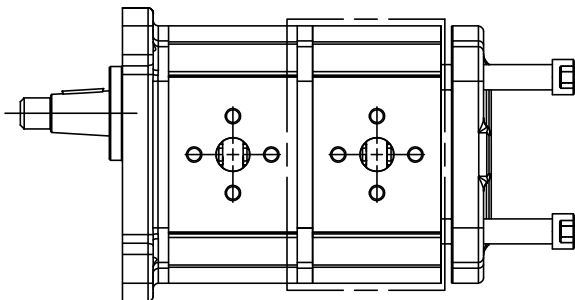

C. Assembling the tandem pump.
Refit the clamp screws.
SCREWS TIGHTENING TORQUE = 60 ± 2 Nm
For length of closure screws = see page 15

DIMENSIONS (side view)

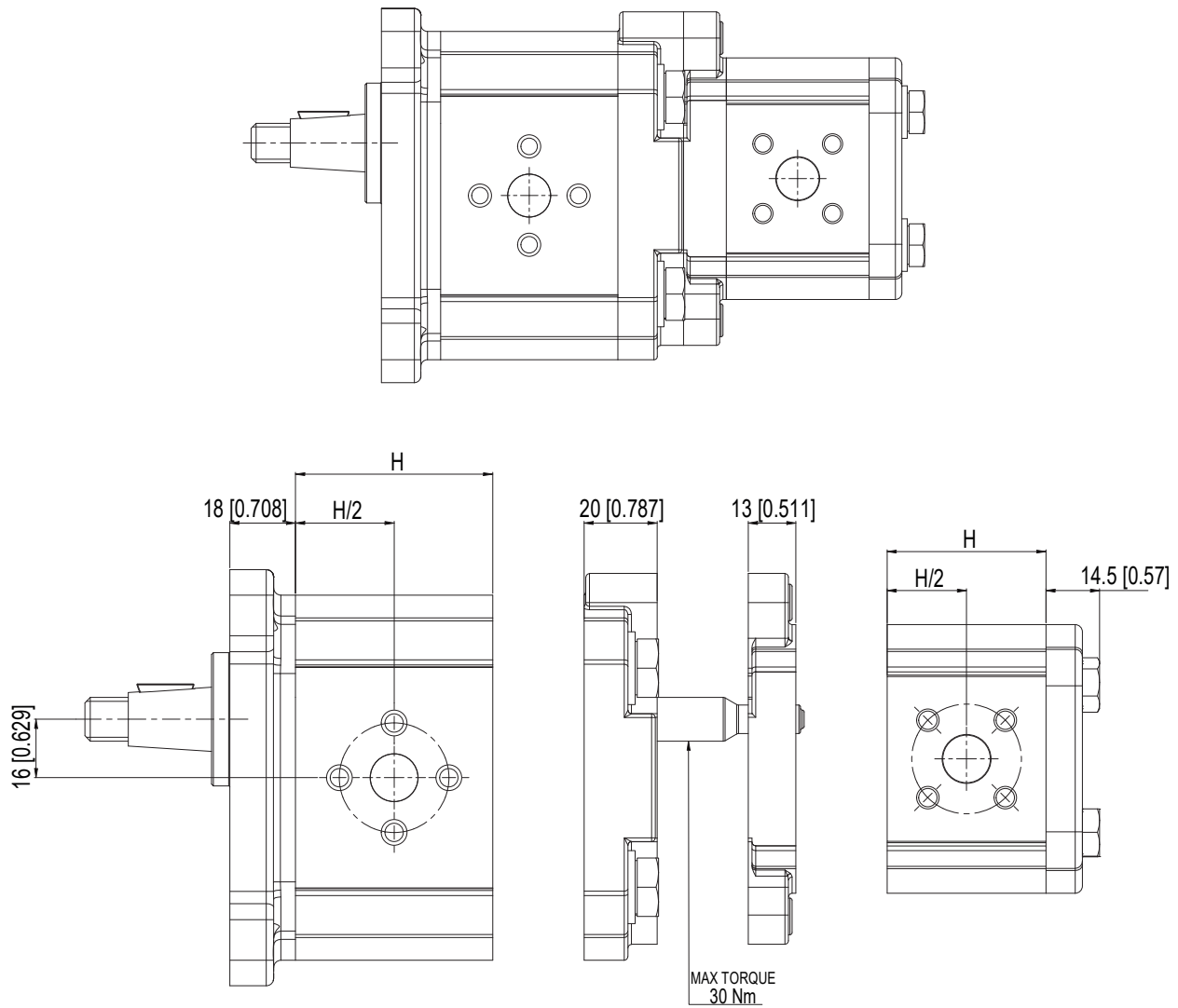

GROUP	PUMP / MOTOR SIZE	H mm (inch)
HY2	04	48.6 (1.913)
	05	49.7 (1.957)
	06	51.5 (2.027)
	08	54.0 (2.125)
	10	56.2 (2.213)
	11	58.4 (2.299)
	14	63.2 (2.488)
	16	66.6 (2.622)
	18	68.2 (2.685)
	20	71.3 (2.807)
	22	82.0 (3.228)
	25	86.6 (3.409)
	28	91.0 (3.582)
	31	96.1 (3.783)

GROUP	SIZE	H mm (inch)
HY1	010	35.7 (1.405)
	015	37.5 (1.476)
	019	39.0 (1.535)
	025	41.3 (1.626)
	031	43.5 (1.712)
	038	46.1 (1.814)
	047	49.5 (1.949)
	053	51.7 (2.035)
	063	55.5 (2.180)
	075	59.2 (2.330)

Code **REV** RELIEF VALVE WITH EXTERNAL DRAIN (ADJUSTABLE SETTING)

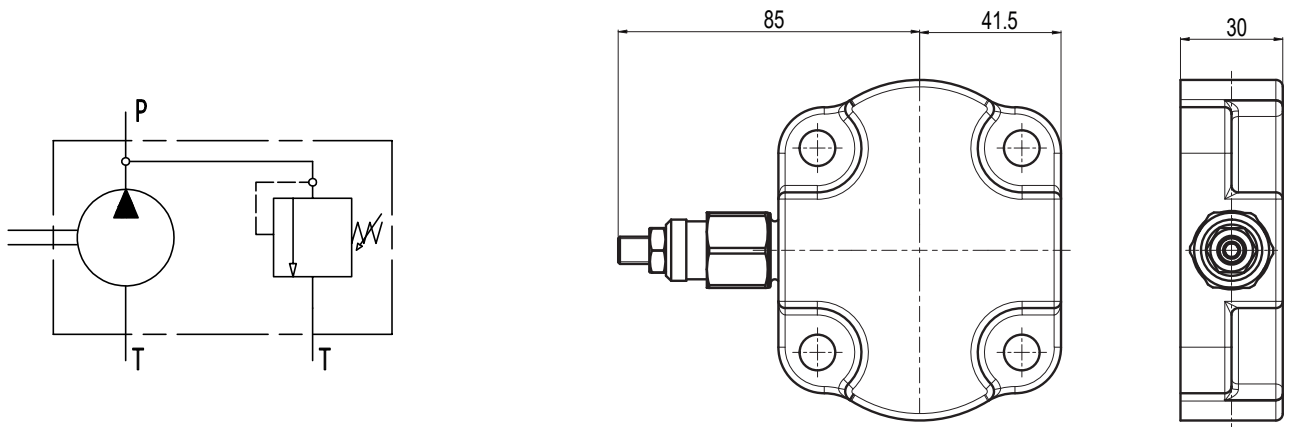

Code **RIV** RELIEF VALVE WITH INTERNAL DRAIN (ADJUSTABLE SETTING)

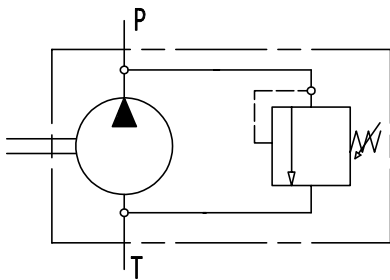

Spring CODE	Pressure setting range bar (psi)
N	10 – 105 (145 – 1522)
B	70 – 210 (1015 – 1885)
G	140 – 260 (2030 – 3770)

Ordering example (add at the end of the pump or motor code) : RIVB(150)

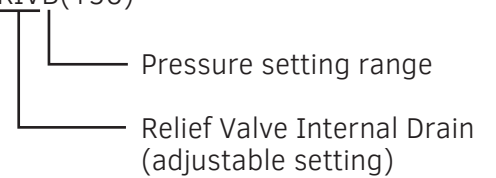

Code **REF** RELIEF VALVE WITH EXTERNAL DRAIN (FIXED SETTING)

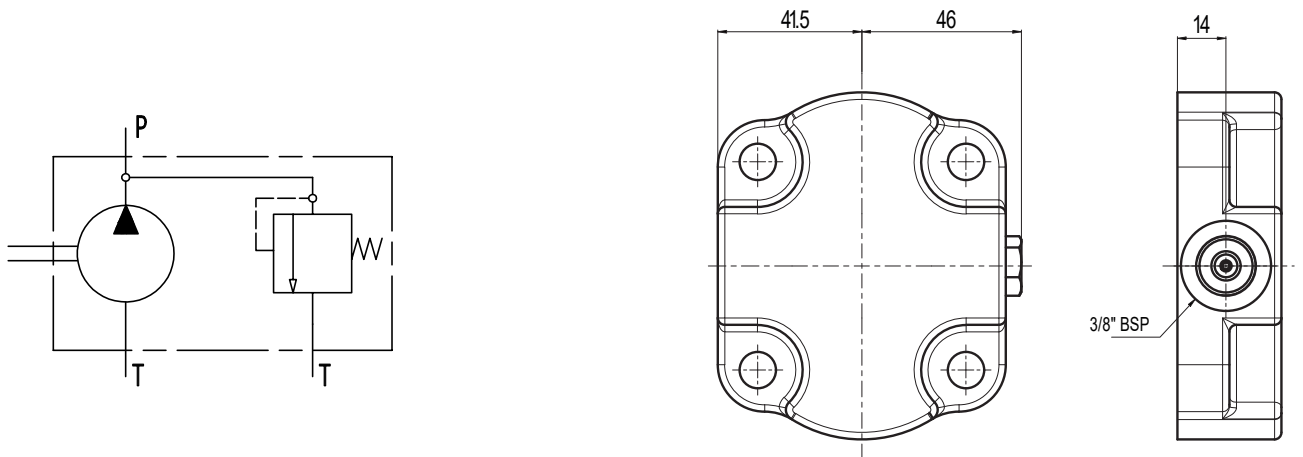

Code **RIF** RELIEF VALVE WITH INTERNAL DRAIN (FIXED SETTING)

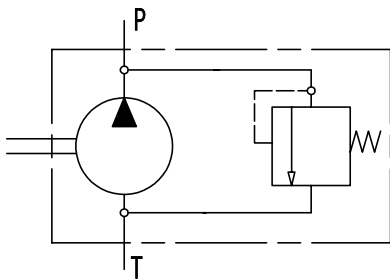

Spring CODE	Pressure setting range bar (psi)
G	101 – 150 (1465 – 2175)

Ordering example (add at the end of the pump or motor code) : RIFG(120)

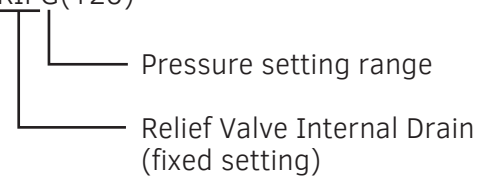

OPTIONS

Code **CH4** 4 MM KEY ON
T2 EUROPEAN TAPERED SHAFT 1:8

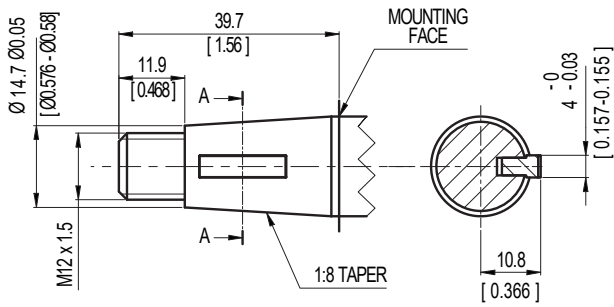

Max Torque = 140 Nm (1240 lbf in)

Code **FSD** SIDE DRAIN ON FLANGE

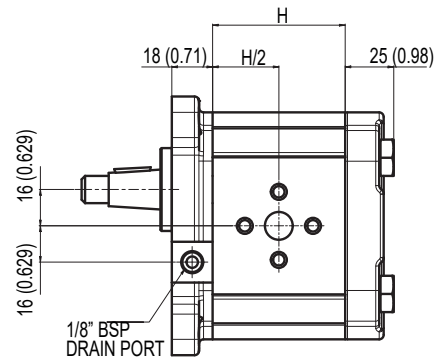

Code **SD** SIDE DRAIN ON COVER

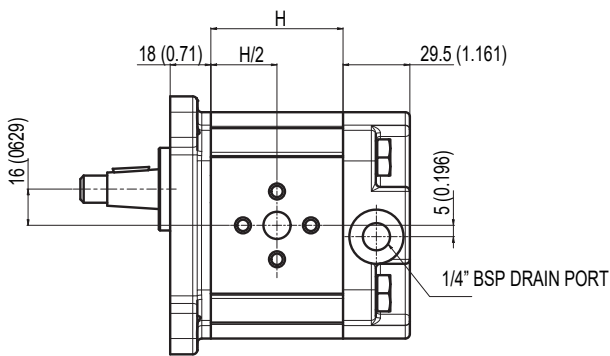

Code **AV** ANTICAVITATION VALVE FOR
SINGLE ROTATION MOTOR

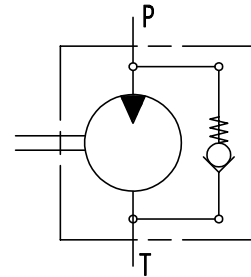

Code **ID** INTERNAL DRAIN FOR
REVERSIBLE UNITS

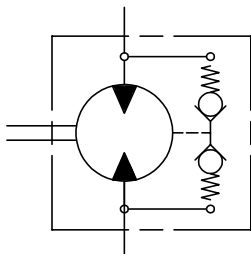

UNITS ROTATING CHANGING INSTRUCTIONS

- A. Clean the pump externally with care
- B. Coat the sharp edges of the drive shaft (2) with adhesive tape and smear a layer of clean grease on the shaft and extension to avoid damaging the lip of the shaft seal when removing the mounting flange
- C. Lay the pump on the working area in order to have the mounting flange turned upside.
- D. Loosen, and remove, the clamp screws (1).
- E. Remove the mounting flange (3), taking care to keep the flange as straight as possible during removal.
- F. Ensure that while removing the front mounting flange, the drive shaft and other components remain in position.
- G. Ease the drive gear (2) up to facilitate removal of bearings (4), taking care that the precision ground surfaces do not become damaged, and removed the drive gear
- H. Remove the driven gear (2) without overturning. The rear flange has not to be removed.
- I. Re-locate the driven gear in the position previously occupied by the drive gear (2).
- J. Re-locate the drive gear (2) in the position previously occupied by the driven gear (5).
- K. Re-locate the bushing (4) without rotating. Refit the front mounting flange (3) turned by 180°.
- L. Refit the clamp screws (1). **SCREW TIGHTENING TORQUE = 60±2Nm - M10**
- M. Check that the pump rotates freely when the drive shaft (2) is turned by hand.
- N. If not a pressure plate seal may be pinched.
- O. The pump is ready for installation with the new direction of rotation.

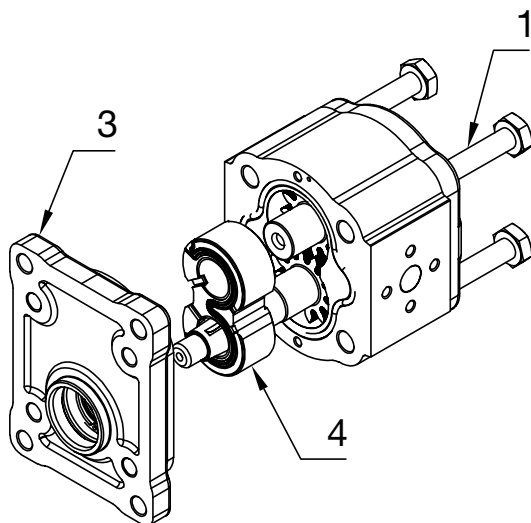
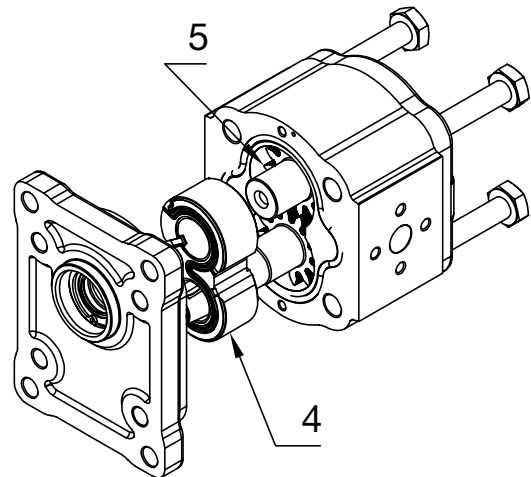
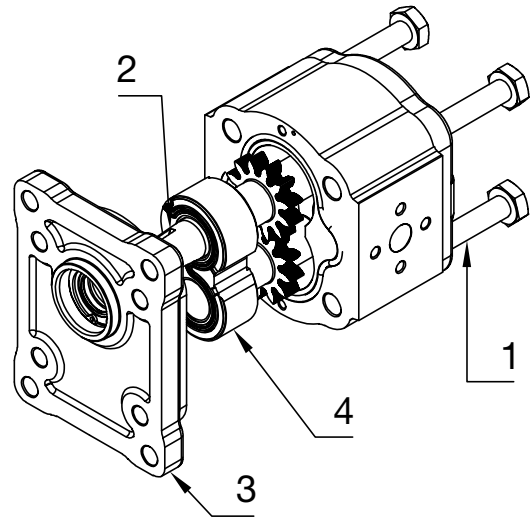

Supported by a worldwide network



CONTACT INFORMATION

EMEA

GERMANY	Hydreco Hydraulics GmbH, Straelen (NRW)	+49 283494303-41	info-de@hydreco.com
ITALY	Hydreco Hydraulics Italia Srl, Vignola (MO)	+39 059 7700411	sales-it@hydreco.com
ITALY	Hydreco Hydraulics Italia Srl, Parma (PR)	+39 0521 1830520	sales-it@hydreco.com
ITALY	Hydreco Srl, San Cesario S/P (MO)	+39 059 330091	cylinders@hydreco.com
NORWAY	Hydreco Hydraulics Norway AS, Nittedal	+47 22909410	post-no@hydreco.com
UK	Hydreco Hydraulics Ltd, Poole, Dorset	+44 (0) 1202 627500	info-uk@hydreco.com

AMERICAS

NORTH/LATIN	Hydreco Inc/ Continental Hydraulics Inc, Shakopee (MN)	+1 952 895 6400	sales@conthyd.com
--------------------	--	-----------------	-------------------

APAC

AUSTRALIA	Hydreco Hydraulics Pty Ltd, Seven Hills (NSW)	+61 2 9838 6800	sales-au@hydreco.com
AUSTRALIA	Hydreco Hydraulics Pty Ltd, Welshpool (WA)	+61 8 9377 2211	reception-wa@hydreco.com
INDIA	Hydreco Hydraulics India Private Ltd, Bangalore	+91 80 67656300	sales-in@hydreco.com

